

Whither Superconductivity?

Superconductivity

The Day Before Yesterday - Yesterday - Today - Tomorrow



Vitaly Lazarevich Ginzburg



Karl Alexander Mueller

"Best wishes, and hang in there, Guys!"

Theory & Modeling

Bob Laughlin's "Theory of Everything" (that matters)

Theory of Everything

$$\mathcal{H} = - \sum_j \frac{\hbar^2}{2m} \nabla_j^2 - \sum_\alpha \frac{\hbar^2}{2M_\alpha} \nabla_\alpha^2 - \sum_{j,\alpha} \frac{Z_\alpha e^2}{|r_j - R_\alpha|} + \sum_{j,k} \frac{e^2}{|r_j - r_k|} + \sum_{\alpha,\beta} \frac{Z_\alpha Z_\beta e^2}{|R_\alpha - R_\beta|}$$

Where's spin, Pauli and Darwin? Ya screwed up, Bob...should'a used the many body Dirac equation! Oh yeah, and maybe Maxwell, Boltzman and Gibbs, too...and Newton's Apple.

- | | | |
|--------------------|-----------------|-----------------|
| • Hydrogen atom | • Proteins | • Flowers |
| • Methane molecule | • DNA | • Trees |
| • Water | • Viruses | • Cows |
| • Air | • Bacteria | • Cheese |
| • Rocks | • Yeast | • Sauce Bernais |
| • Concrete | • Slime mold | • Computers |
| • Steel | • Butterflies | • Television |
| • Glass | • Sharks | • Cars |
| • Plastic | • Rats | • Jets |
| • Buildings | • Lawyers | • Lawnmowers |
| • Cities | • Ebola virus | • Scurvy |
| • Continents | • Legislatures | • Spotted Oats |
| | • Civilizations | ... |

The crunch comes when \sum_i with $i \geq 3 \rightarrow$ "thermodynamic limit."

"Size Matters !"

"Naked BCS"

$$T_C = a\Theta e^{-\frac{1}{\lambda - \mu^*}}$$

Where $\lambda k\Theta \ll E_F$

T_C = Critical Temperature

Θ = Boson Characteristic Temperature

λ = Fermion-Boson Coupling Constant

μ^* = Fermion-Fermion Repulsion

a = "Gap Parameter, $\sim 1-3$ "

When “electron-electron” interactions are involved,
the phrase “pairing glue” can be a dirty word!

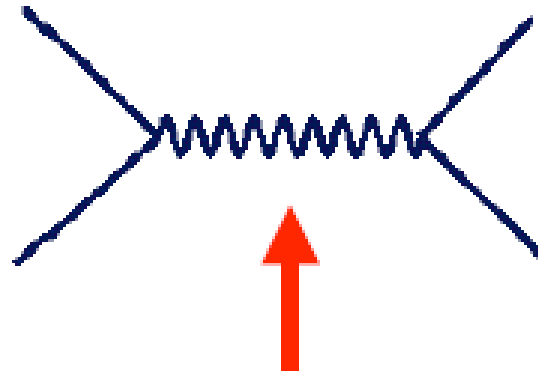

Insert your favorite “on” here

(phonon, magnon, exciton, plasmon, anyon, moron ...)

“Put-on !”



Really High-Tc

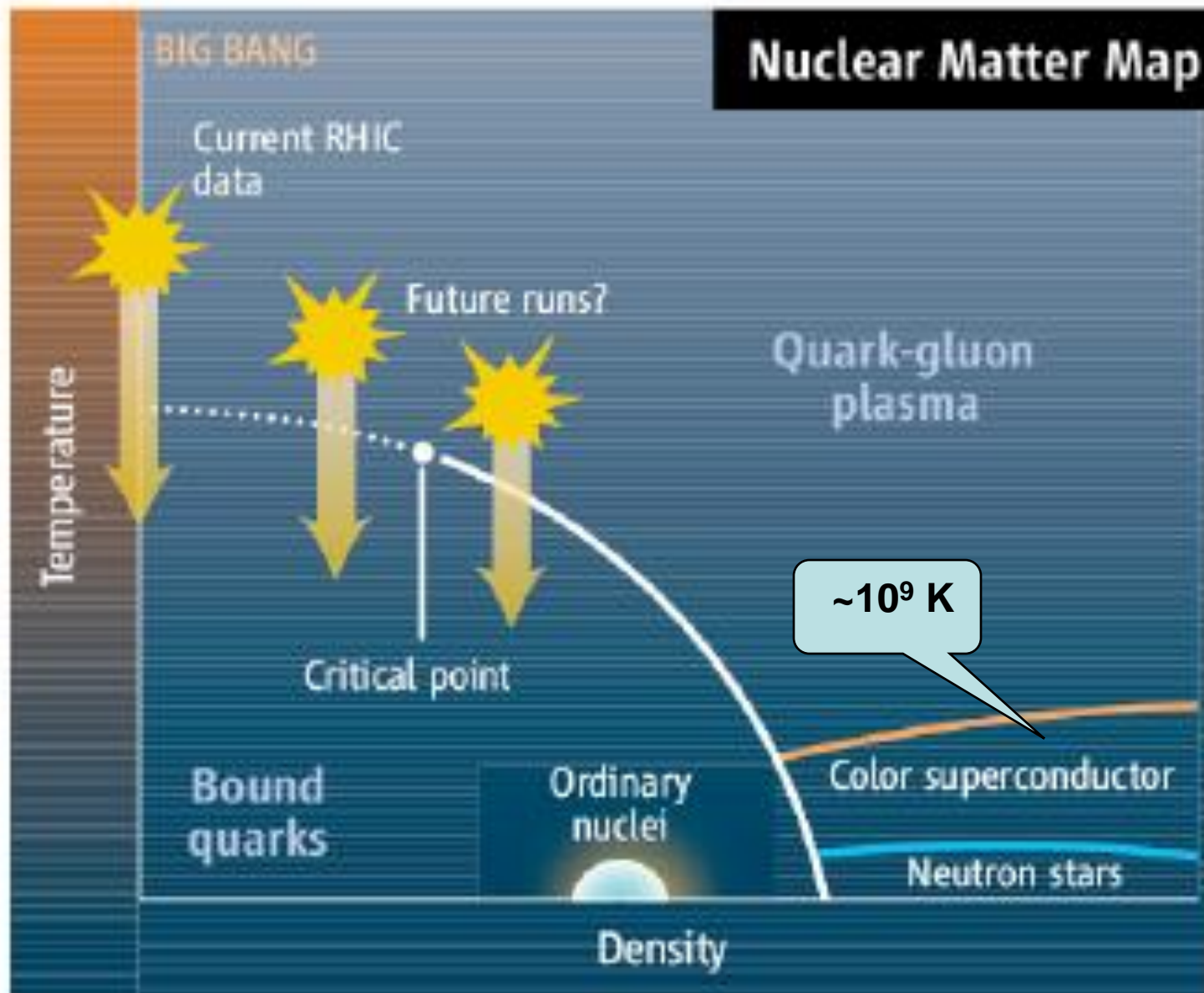

Electron-Phonon Coupling a la Migdal-Eliashberg-McMillan

(plus Allen & Dynes)

$$H_{el-ph} = \sum_{\mathbf{k}q\nu} g_{\mathbf{k}+\mathbf{q},\mathbf{k}}^{q\nu,mn} c_{\mathbf{k}+\mathbf{q}}^{\dagger m} c_{\mathbf{k}}^n (b_{-\mathbf{q}\nu}^{\dagger} + b_{\mathbf{q}\nu}) \quad (1)$$

First compute
this via DFT...

$$\alpha^2 F(\omega) = \frac{1}{N(\epsilon_F)} \sum_{mn} \sum_{q\nu} \delta(\omega - \omega_{q\nu}) \sum_{\mathbf{k}} |g_{\mathbf{k}+\mathbf{q},\mathbf{k}}^{q\nu,mn}|^2 \times \delta(\epsilon_{\mathbf{k}+\mathbf{q},m} - \epsilon_F) \delta(\epsilon_{\mathbf{k},n} - \epsilon_F), \quad (2)$$

$$\lambda = 2 \int \frac{\alpha^2 F(\omega)}{\omega} d\omega = \sum_{q\nu} \lambda_{q\nu}, \quad (3)$$

$$\lambda_{q\nu} = \frac{2}{N(\epsilon_F)\omega_{q\nu}} \sum_{mn} \sum_{\mathbf{k}} |g_{\mathbf{k}+\mathbf{q},\mathbf{k}}^{q\nu,mn}|^2 \times \delta(\epsilon_{\mathbf{k}+\mathbf{q},m} - \epsilon_F) \delta(\epsilon_{\mathbf{k},n} - \epsilon_F). \quad (4)$$

Then this...

Quantum-Espresso (Democritos-ISSA-CNR)

<http://www.pwscf.org> Grazie!

Polysulfur Nitride: The World's First 330 Degree Superconductor !

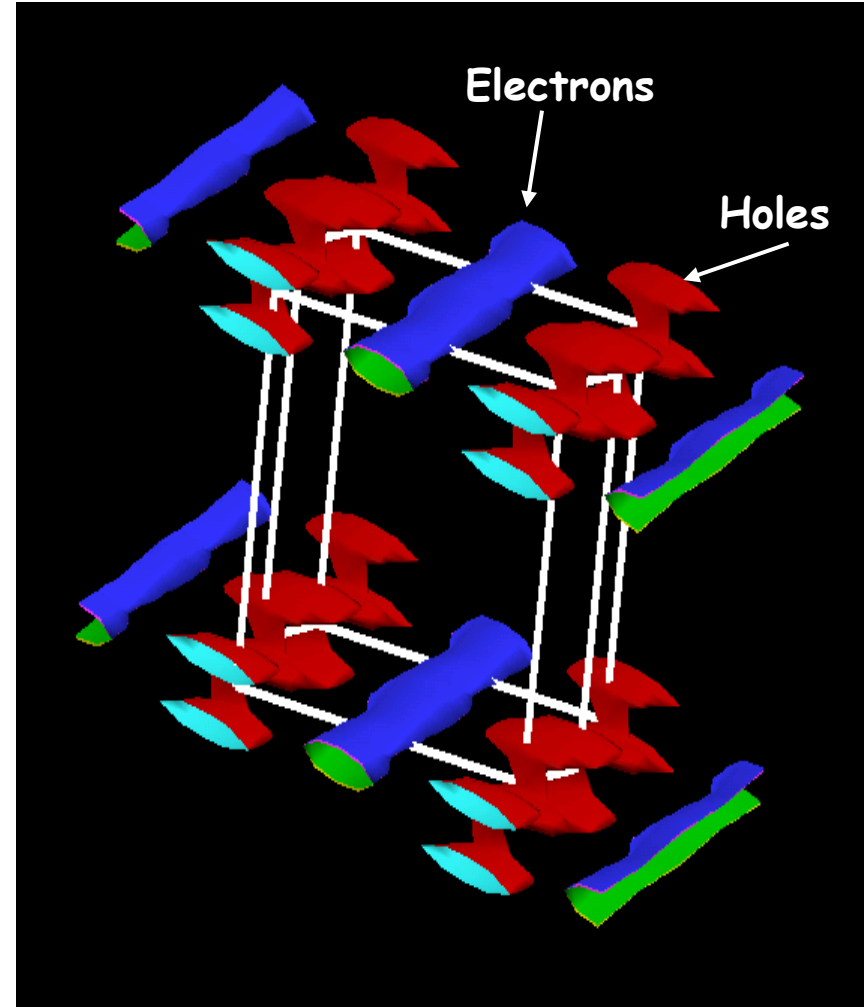
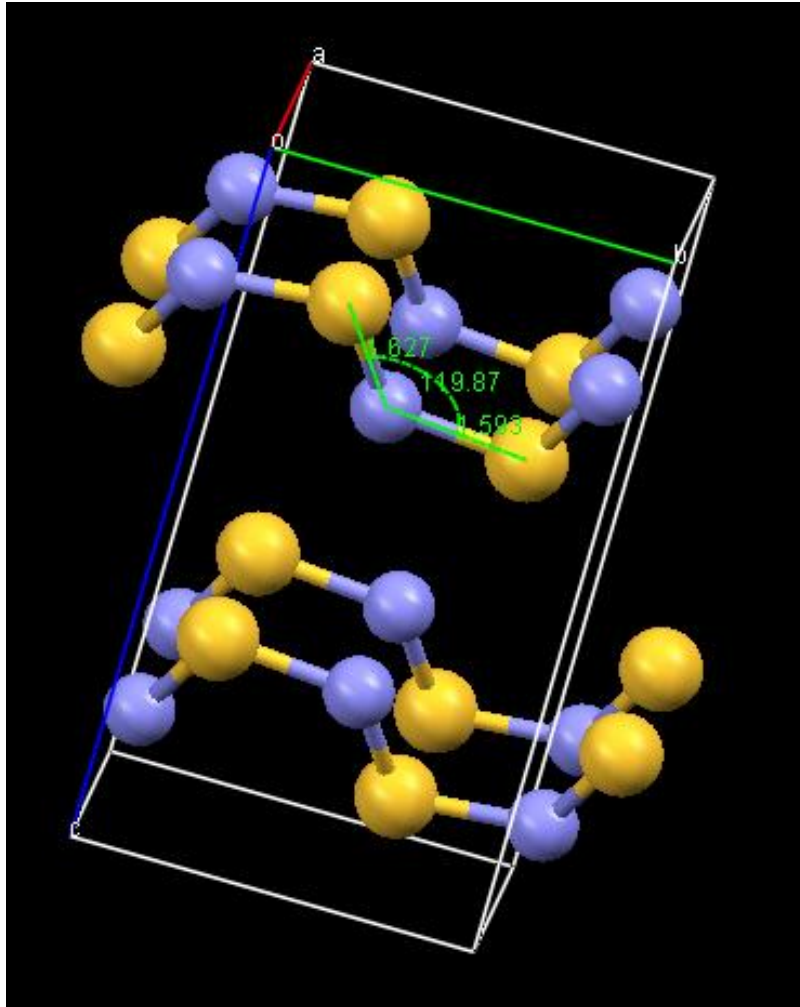

Legal Disclaimer: The Temperature Units are Millikelvin.

So...

- Now we can compute the sc phase diagram of Al, Nb, MgB₂, etc., as accurately as can be measured.
- Then has phonon-mediated superconductivity in s-p (light elements...some not so light) systems become "solved science?"
- Maybe...ask Warren Pickett.
- Unresolved: ultra-strong λ and flux dynamics.

What to do next?

- Develop DFT algorithms to compute "exotic" pairing mechanisms, analogous to e-p.
- Especially polarization ("exciton") and magnetic ("all flavors," particularly "negative-U").
- Marvin ?

Materials & Methods

Guidance from Our Elders

- *"Don't listen to theoreticians"* (B. Matthias, ca. 1970s).
- *"To make a long story short, searches for high-temperature superconductors, especially with the existing obscurities in the area of theory, may lead to unexpected results and discoveries"* (V. L. Ginzburg, 1984).
- *"At the extreme forefront of research in superconductivity is the empirical search for new materials"* (M. R. Beasley (1983), as communicated by K. A. Mueller and J. G. Bednorz, (1986)).
- *"If you find an old metal laying around in the literature, try cooling it down,"* (P. M. Grant, 1976).

Exactly What is a "Superconductor?"

- Does it have to be a "perfect conductor?"
 - i.e., zero TAFF
- Does it have to exclude flux (Meissner)?
- Or does it only need to be a "real good conductor ("ultraconductor")?"
 - $200\times \sigma_{Cu}$ @ 300 K @ 1000 Hz
 - Ballistic CNTs
 - Sliding P-F CDWs
 - Charged Solitons
 - ???

Materials Pathways

- Light Elements
- Heavy Elements
- Many Elements
- All Elements

- *COMBINATORIAL!*

Fabrication

Superconductor Sandwiches

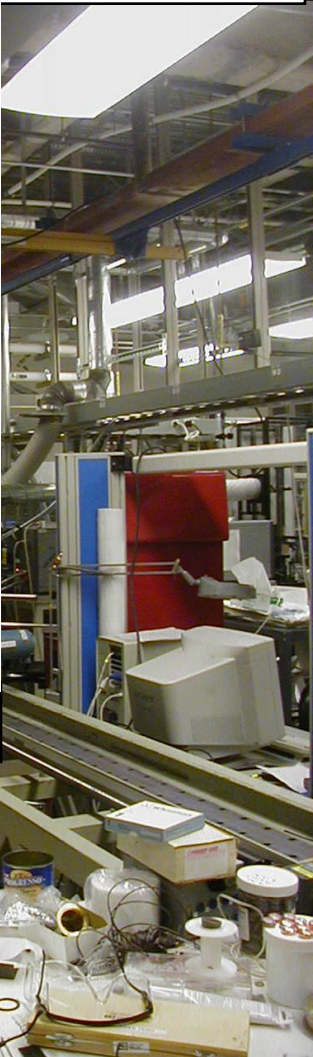
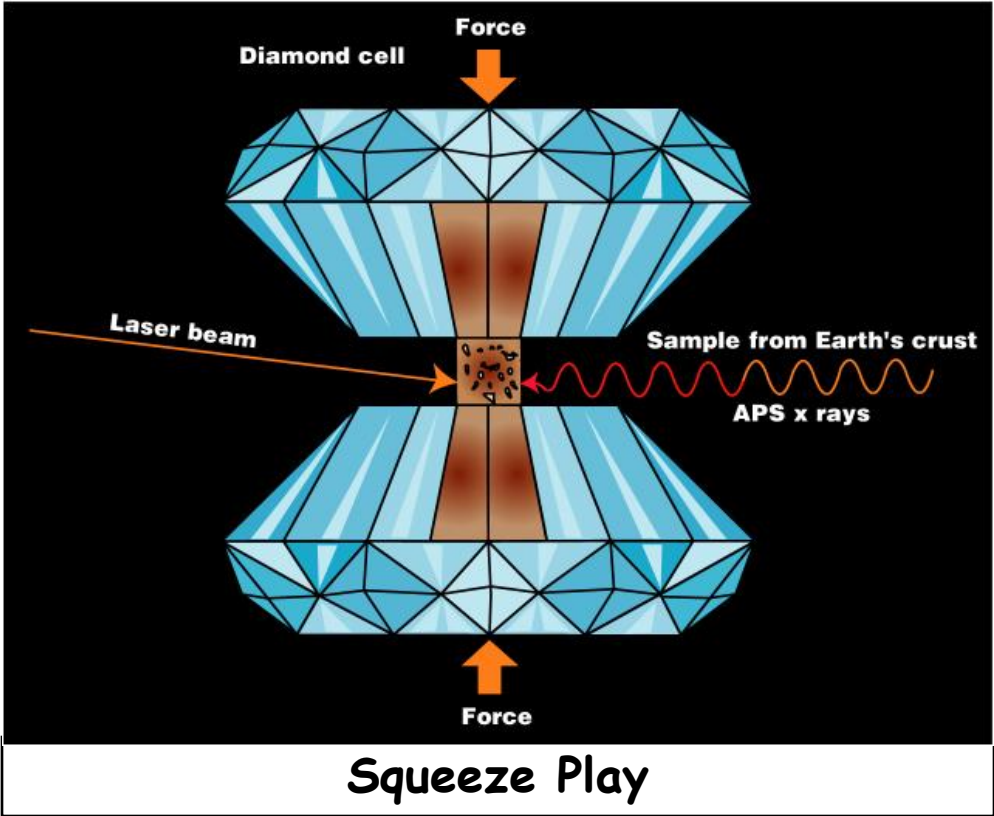

'em 'n' Beat 'em

NanoMachining

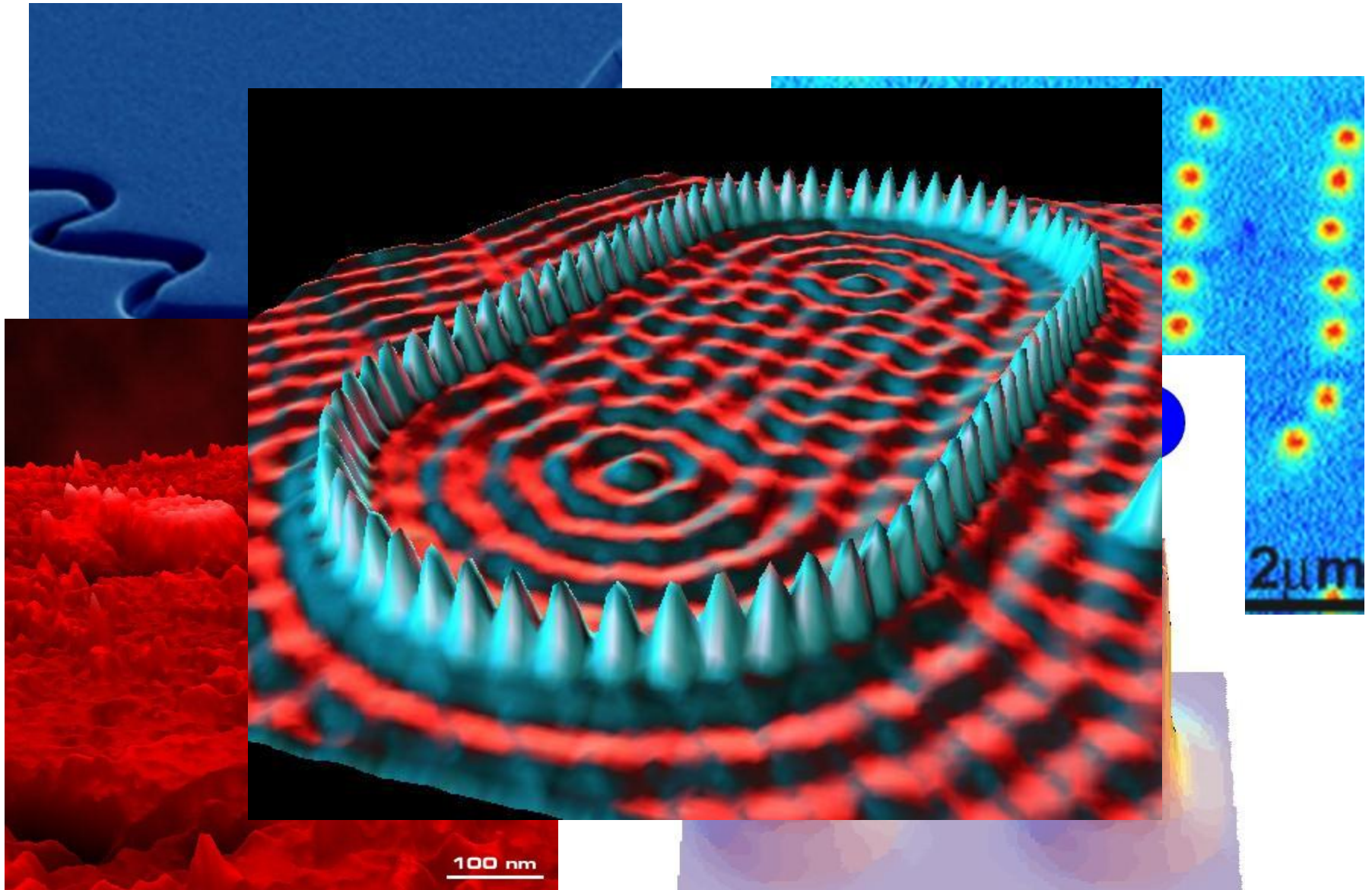

“Magic Carpet”

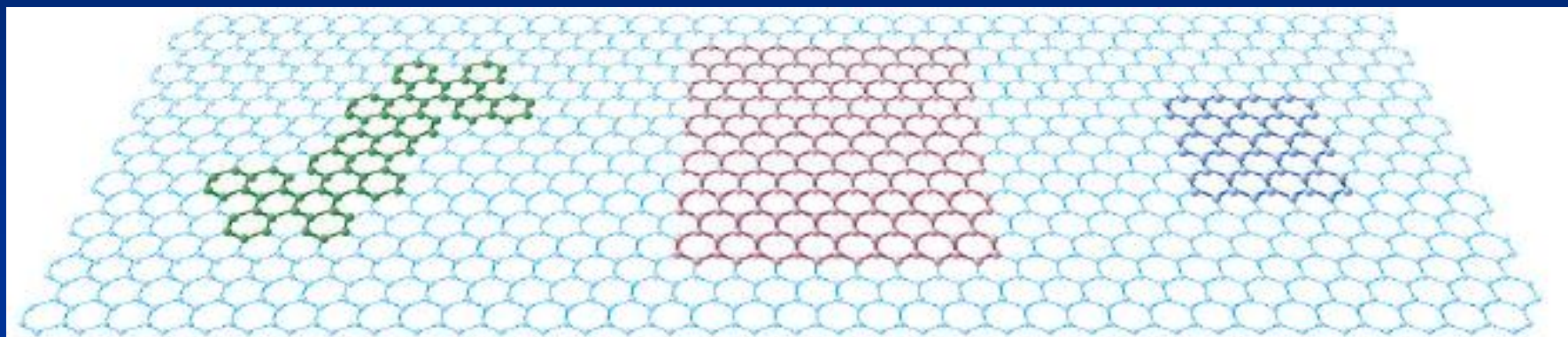

Applications

Low-Tc Today

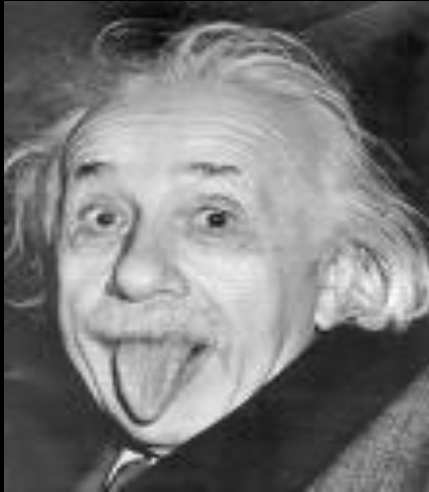

Quantum
Computing



Electronics

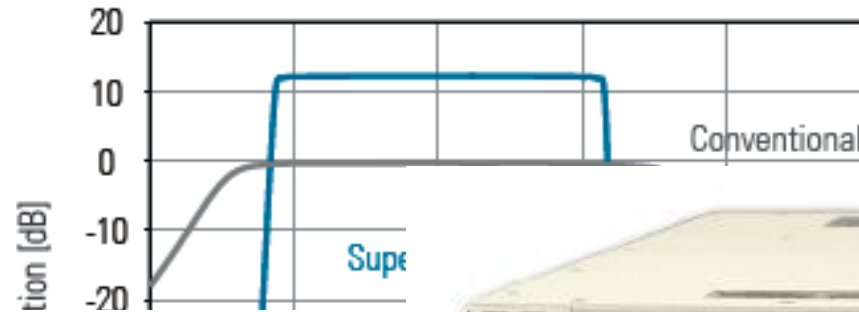
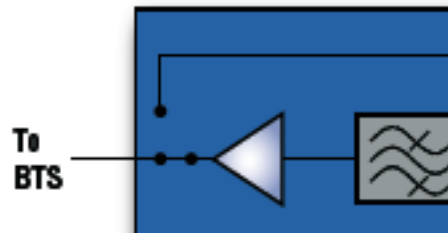

“A room temperature device !”

Wire

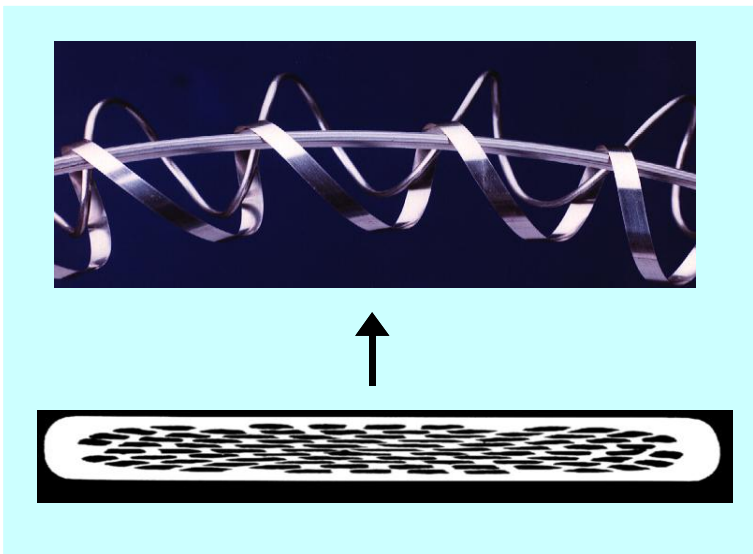

Gen 2

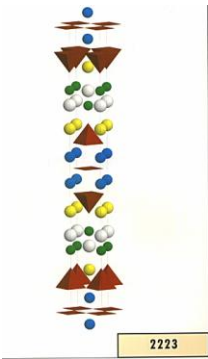
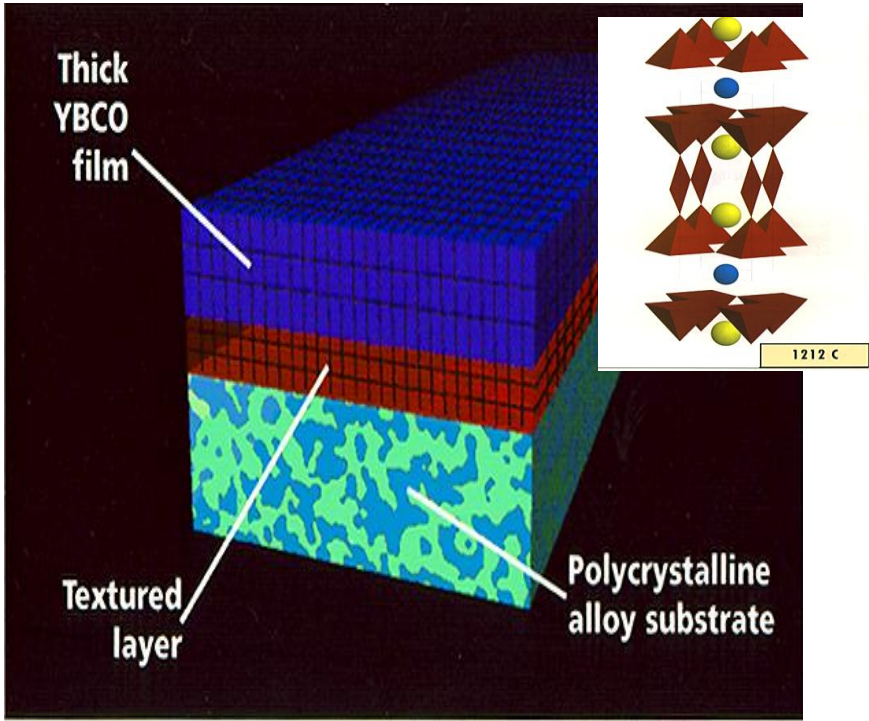

Gen 1

Major Players: US, Japan, China

Wire Performance

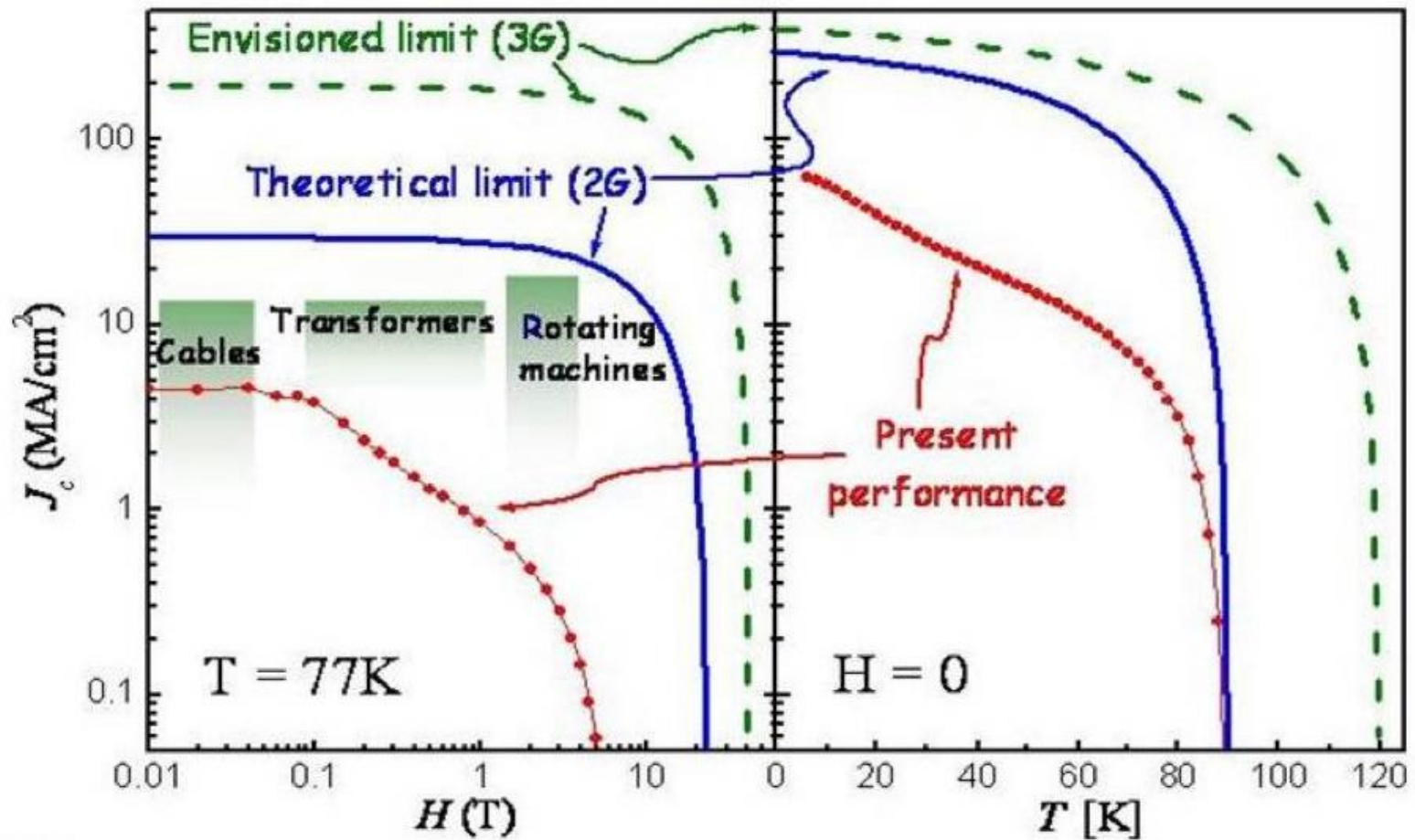

Rotating Machinery

Courtesy AMSC

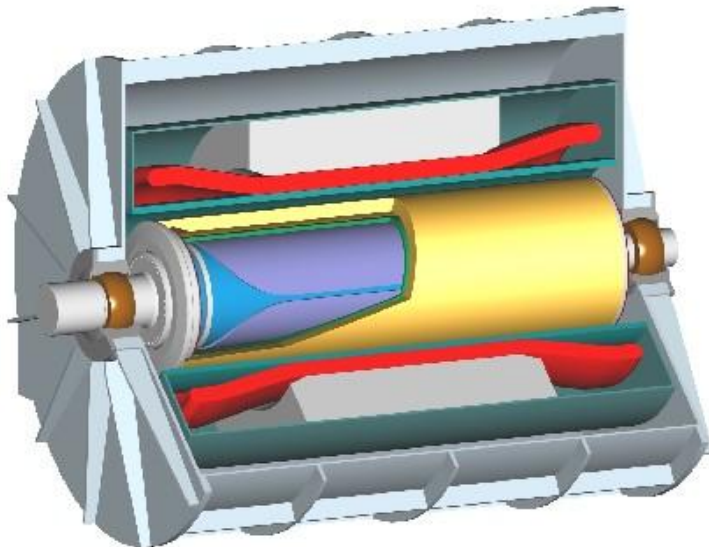
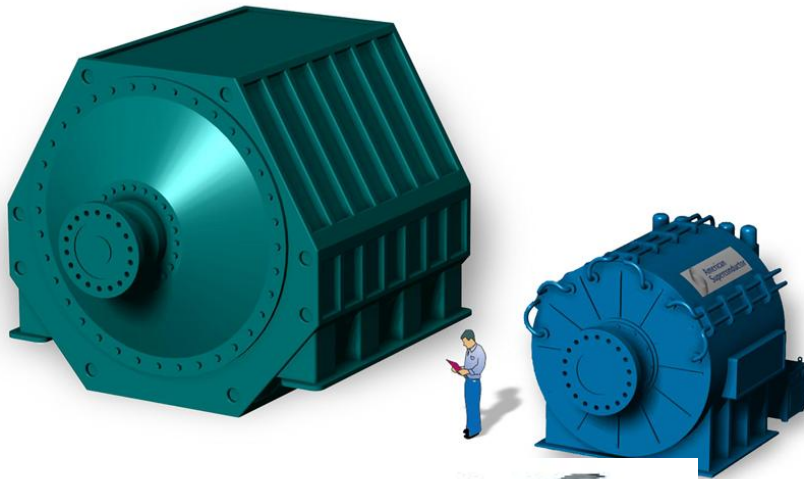

Major Players:

- AMSC
- SEI

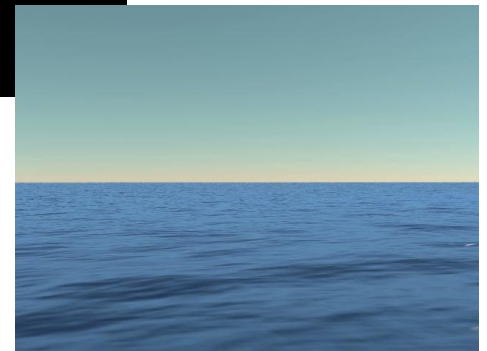

Cables



GUIDE

Nexans



Secure Super Grids



"You can't always get what you want..."



“...you get what you need!”



Where there is no vision,
the people perish...

Proverbs 29:18